

# FILTRAČNÍ VOZÍK

## DEPUROIL

### Popis:

- ideální pro denní použití
- kompaktní
- tichý provoz cca 70dB
- indikace zanešení
- 5 metrů el. kabelu
- sací hadice se spirálou

PIUSI DEPUROIL filtrační vozík pro filtraci olejů a nafty. Čerpadlo žene kapalinu skrze filtr (výměnou filtrační vložky) a díky manometru lze sledovat zanešení této filtrační vložky.

### PERFORMANCE

**AC**  
VOLTAGE  
POWER



DEPUROIL

### PACKAGING

CODE	WEIGHT		PACKAGING			
	KG	LBS	MM	INCH	PCS/PALLET	PCS/BOX
00050300A	28	61,7	600X290X300	23,6X11,4X11,8		1
FO0503100	28	61,7	600X290X300	23,6X11,4X11,8		1



FILTRATION



AIR



ANTIFREEZE



AdBlue®



BIODIESEL



DIESEL



FOOD



GASOLINE



GREASE



KEROSENE



OIL



WATER



WINDSCREEN

CHART

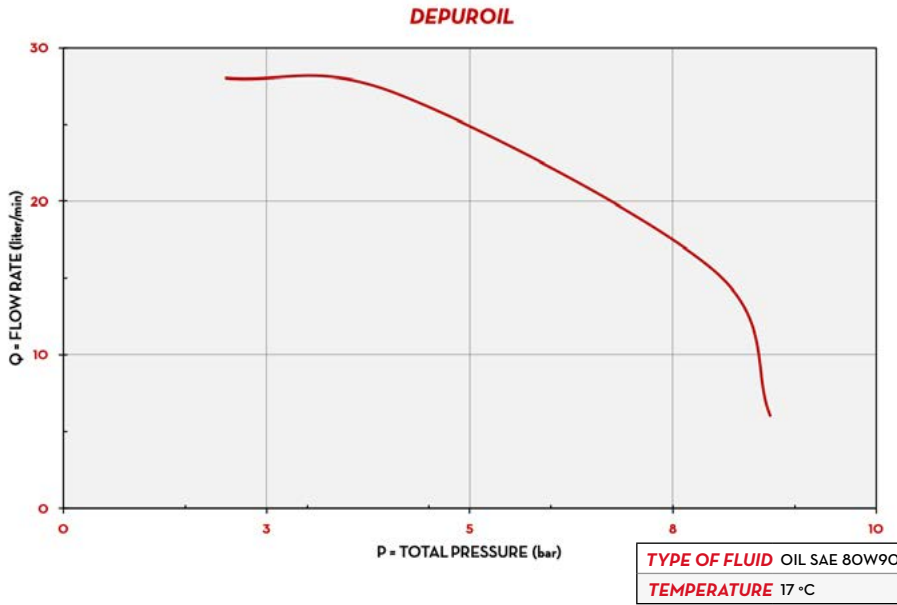

IN THE BOX

- DEPUIROIL
- FILTER CARTRIDGE
- SUCTION HOSE
- DELIVERY HOSE
- INSTRUCTION MANUAL

DETAILS

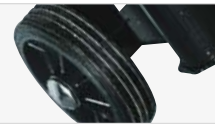

LARGE DIAMETER WHEELS



STURDY STRUCTURE

DIMENSIONS

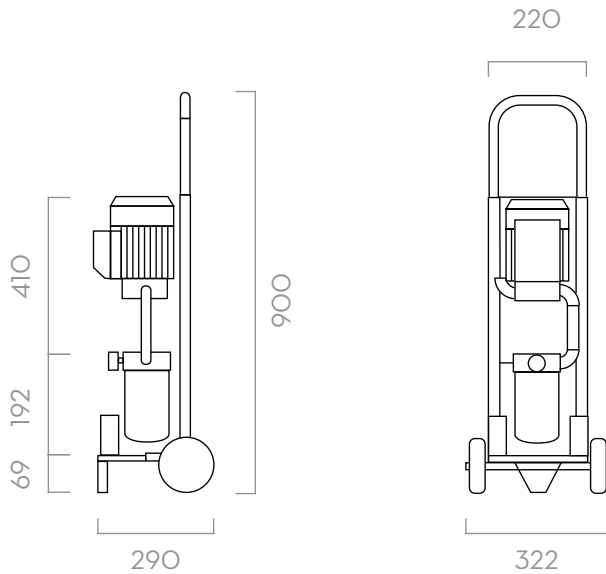

Dimensions expressed in millimeters

MATERIALS

- BODY: CAST IRON
- ROTOR: SINTHERED STEEL
- VAINS: TECHNOPYLIMER
- SHAFT: STEEL
- FILTER: ABSORBENT FILTERING PAPER

TECHNICAL DATA

CODE	DESCRIPTION	FLUIDS TYPE	FLOW RATE		VOLTAGE			PUMP	HOSE LENGHT		FILTERING CAPACITY
			L/MIN	GPM	AC V./HZ DC VOLT	POWER WATT	AMP. MAX.		DELIVERY /FT	SUCTION M/FT	
00050300A	DEPUIROIL M 230V/50HZ		20-25	5,28-6,6	230/50	1350	6,2	VISCOMAT 70	2 / 6,5	2 / 6,5	10
FO0503100	DEPUIROIL 60		50	13	230/50	1350	6,2	VISCOMAT 90	2	2	10

DEPUIROIL